

# Reservoir Committee and Authority Board Meeting

Benefits and Obligations Workshop

May 8, 2026



# For Today

## Issue for Discussion

- **Finalizing the Benefits and Obligations (B&O) Contract:** Resolving the remaining key policy and operational issues necessary to finalize the contractual framework for Project Phases 3, 4, and 5.

## Policy Direction Needed

- **Concurrence on Staff Recommendations:** Review and provide direction on proposed revisions to the B&O Contract, JPA, and Bylaws to ensure they align with Participant expectations and Project goals.

# Workshop Goals

- Agree in principle on concepts, let's avoid wordsmithing
  - Expectation: get to “Good Enough” and general consensus: not everyone will get exactly what they want
- Where alternate direction to staff recommendation is given,
  - Form clear board direction to staff on what needs to be done
  - Identify the key principles and any follow-up needed

# Suggested Ground Rules

- Many of you have support staff with you:
  - Please keep your internal discussions to yourselves, you can leave the room and use the back office if needed
  - Maintain your board member as your spokesperson, but others from your agency can comment and ask questions
- One person has the floor, the chairs will facilitate orderly discussion
- We have more than normal attendees so make your comments brief and to the point
- Let's avoid distracting side conversations
- Meeting breaks can be taken when needed for caucusing with others, be reminded of Brown Act requirements

# Today, we will walk through the following issue papers

- Issue 1 Governance
- Issue 2 Downstream Capacity
- Issue 3 Payment Annexes
- Issue 4 Partner Facilities
- Issue 5 Release of Water/Point of Delivery

# Governance

## Issue Paper 1



# Summary of Comments and Staff Recommendation

## Comment/Issue

- There are concerns previously expressed about durability of delegated powers.
- There are new concerns that aim to establish contractual rights to delegated powers.

## Staff Recommendation

- Concur with revisions to contract provisions reviewed under agenda item 2.4 of the March 20, 2026 Sites Board meeting
- Refer the new Participant comments to the Governance Ad Hoc and request recommended Board action from this group on these new items to occur at the June 2026 Sites Board meeting.

# Rationale for Staff Recommendation

- The Governance Ad Hoc was started by the Board in August 2022 to evaluate governance proposals.
- The items in agenda item 2.4 of the March 20, 2026 Board meeting were
  - requested by Participants to be discussed at this workshop
  - previously reviewed and concurred by the Governance Ad Hoc
- Referring the new items to the Governance Ad hoc is consistent with past practice
- Does the Board have any particular guidance or requests related to an Ad Hoc referral of new items?

# Contract Sections Affected

- See Attachment A and B

# Downstream Capacity

Issue Paper 2



# Summary of Comments and Staff Recommendation

## Comment/Issue

- Participants want Downstream Capacity to be a separate "interest" or "ownership" asset rather than a "share".
- Current "share" concepts are viewed by some as inconsistent with their rights to control and depend on capacity.

## Staff Recommendation

- Revise the B&O Contract to include "Downstream Capacity Interest" as a distinct asset.
- Allow this interest to be used, sold, transferred, or leased independently of a Participant's Base Capacity.

# Rationale for Staff Recommendation

- **Participant Control:** This approach follows the "Beneficiary Pays Principle," giving Participants direct control over their capacity.
- **Certainty:** It eliminates the potential for a Participant's downstream capacity to be reduced by transactions they aren't part of.
- **Flexible Operation:** Retains general use provisions in the B&O Contract while allowing operational details to remain flexible in the Operations Plan.
- **Dual Assets:** Participants will effectively hold two distinct assets—Base Capacity and Downstream Capacity—providing better financial and operational clarity.

# Contract Sections Affected

- **Global Revisions:** References to "Downstream Capacity Share" will be changed to "Downstream Capacity Interest" throughout the contract.
- **Definition Section:** The definition of "Downstream Facilities Capacity Interest" will be updated.
- **Section 3.6:** Revised to reflect the grant of ownership/interest in Downstream Facilities.
- **Section 8.2.1:** Subsections (g) and (h) will be removed to eliminate restrictions on independent sales and transfers.

# Contract Sections Affected

## Proposed language

*Throughout the Contract, references to “Downstream Capacity Share” will be revised to “Downstream Capacity Interest” and conforming changes will be made globally as needed.*

*The definition of “Downstream Capacity Interest” will be revised as follows:*

**Downstream Facilities Capacity Interest: Means** ~~a share expressed in percentage based on the ratio of each Storage Partner’s Base Facilities Capacity Interest to the sum of the total Base Facilities Capacity Interest of all Storage Partners with Downstream Facilities Capacity Share, specified in the Project Specific Information, as modified from time to time in accordance with this Contract. [Note: All Participants will be able to acquire Downstream Capacity at the time they make their commitment to purchase Base Capacity. This is a “toggle” that is, the agency either wants Downstream Capacity or not. If the agency opts into Downstream Capacity, it will be allocated as a portion of all the entities (including the State and Bureau) that sign up for Downstream Capacity in proportion to Base Capacity Interest.]~~ Means the undivided capacity right of those Storage Partners indicated in the Project Specific Information to convey and divert Sites Water in each of the Downstream Facilities granted by the Sites Authority and owned by the Storage Partners in accordance with Section 3.6, and in the pro-rata share set out for each Storage Partner in the Project Specific Information and subject to the Sites Water Right, Applicable Law and Governmental Approvals.

# Contract Sections Affected

## Proposed language continued

*Revise Section 3.6 as follows:*

The Sites Authority ~~shall allocate~~ **hereby grants** to each ~~Participant who requests to participate in the funding and use of Downstream Facilities~~ **those** Participants indicated in the Project Specific Information as holding a Downstream Facilities Capacity Interest, and such Participants shall own, a Downstream Facilities Capacity ~~Share~~ **Interest** in the amounts described in the Project Specific Information and otherwise in accordance with this Contract.

# Contract Sections Affected

## Proposed language continued

*Remove Section 8.2.1(g) and (h) which currently read:*

~~(g) should a Participant without a Downstream Facilities Capacity Interest wish to sell some or all of its Base Facilities Capacity Interest to another Storage Partner that will need to utilize Downstream Facilities to receive their Sites Water, the amount of first priority use for all Downstream Facility users will be adjusted by recalculating the Downstream Facilities Capacity Share in accordance with the formula set out in the Operations Plan. Prior to such sale, (i) the holders of all Downstream Facilities Capacity Shares must approve the transaction (such approval not to be unreasonably withheld); and (ii) Sites Authority may assess a “buy-in” fee on the buyer that would be distributed to the Storage Partners with Downstream Facilities Capacity Share before the sale and subsequent reallocation. The “buy-in” fee would be based on the capital costs of the Downstream Facilities prior to the sale and, if assessed, is intended to compensate those Participants that funded the construction of the Downstream Facilities; and~~

~~(h) Downstream Facilities Capacity Share cannot be sold independently of the associated Base Facilities Capacity Interest.~~

# Additional Terms Related to Acquirer

Issue Paper 3



# Summary of Comments and Staff Recommendation

## Comment/Issue

- A subset of Participants (SWP Participants) desire to contract with DWR to acquire Sites Water on their behalf.
- Serving as the "Acquirer" requires DWR to be a signatory and requires specific contractual refinements to effectuate the approach.

## Staff Recommendation

- Incorporate B&O revisions that clarify the roles and responsibilities between the Authority, DWR, and SWP Participants.
- Add a new "Appendix X" to define the specific administration of these rights and responsibilities.

# Rationale for Staff Recommendation

- **No Impact on Others:** The changes do not modify the core rights, costs, or benefits of other Participants or State/Federal uses.
- **Administrative Clarity:** These revisions refine the structure necessary to implement DWR's role without changing the basic participation framework.
- **Internal Coordination:** SWP Participants responsible to coordinate with DWR and the Authority, which may ease timing and scheduling for other Participants coordinating Sites deliveries with DWR
- **Default Protections:** Provides a clear path for defaulted capacity to remain within the DWR pool for SWP Participants broader project releases.

# Flagged Sections in Proposed Appendix X to Consider

- **Section 6.1:** Modified dynamics for capacity transactions (Right of First Refusal for SWP Participants within Acquirer Pool).
- **Section 7:** Requirements for capacity use coordination with DWR.
- **Section 12.3:** Adjustments to default reallocation procedures for the Acquirer pool.
- **Section 14.1:** DWR has unilateral ability to terminate as the Acquirer
- **Section 16:** Appendix X includes unique amendment processes.

\* References are to where addressed in the Appendix X

# B&O Contract Sections Affected

- **Section 1.3.1, 6.1.2** - Pass Through Limitations on DWR Financial Obligations
- **Section 1.3.3 – 1.3.6:** DWR retains independent statutory authorities; ie remains ex officio, can take adverse positions to the Authority

\* References are to where addressed in the Dec 2025 B&O Contract

# Partner Facilities

Issue Paper 4



# Focus for today

This workshop is focused on B&O Contract terms and does not serve as a negotiation of the Facility Use Agreements (FUAs) themselves. Specific negotiations for facility agreements are separate, ongoing processes led by a designated negotiator. Consequently, comments regarding specific performance metrics or assurances from Facility Partners must be addressed within those separate negotiations rather than this session.

# Summary of Comments and Staff Recommendation

## Comment/Issue

- The Project relies on infrastructure (Partner Facilities) owned and operated by agencies other than the Sites Authority.
- Participants want the Authority to take formal responsibility for Project-wide operational continuity.

## Staff Recommendation

- Clarify the Authority's obligation to enter, maintain, and ensure compliance with Facility Use Agreements (FUAs).
- Commit to "best efforts" consistent with Good Industry Practice to maximize project benefits.

# Rationale for Staff Recommendation

- **Reasonable Assurance:** Provides the operational certainty Participants need while acknowledging the Authority's legal limits on controlling third-party facilities.
- **Operational Oversight:** The Reservoir Management Board (RMB) has delegated power to independently oversee Project operations and implement agreements (except if violating the law or agreement terms).
- **Contingency Planning:** Added provisions for RMB to develop alternative conveyance affords Participants another option within their control.
- **Standard of Care:** Sets a performance standard - "Good Industry Practice".

# Contract Sections Affected

- **Section 4.13:** Revised to explicitly mandate the maintenance of and compliance with Partner Agreements.
- **Bylaws (Sections 12.3.2 & 12.3.4):** These sections would further clarify facility agreements are amended as "Shared Decisions" (see governance new provisions).
- Add a new provision that where deemed reasonable and necessary by the RMB that new conveyance plans must proceed.

# Contract Sections Affected

## Proposed language continued

*Revise Section 4.13 of the B&O Contract to read as follows:*

### Maintenance and Compliance with Partner Agreements

The Sites Authority shall (i) enter into, (ii) maintain, and (iii) ensure compliance with, each applicable Partner Agreement necessary for the operation of the Project in accordance with this Contract, the Operations Plan and Good Industry Practice. In performing its obligations under this Contract, the Sites Authority shall ensure terms of the Partner Agreements are complied with.

Staff also recommends including provisions in the B&O Contract that clarify that where deemed reasonable and necessary by the RMB, the Sites Authority shall develop and execute a plan approved by the RMB to proceed with alternative conveyance should such action be deemed necessary at any point in the future.

# Authority Obligations to Participants for All Agreements

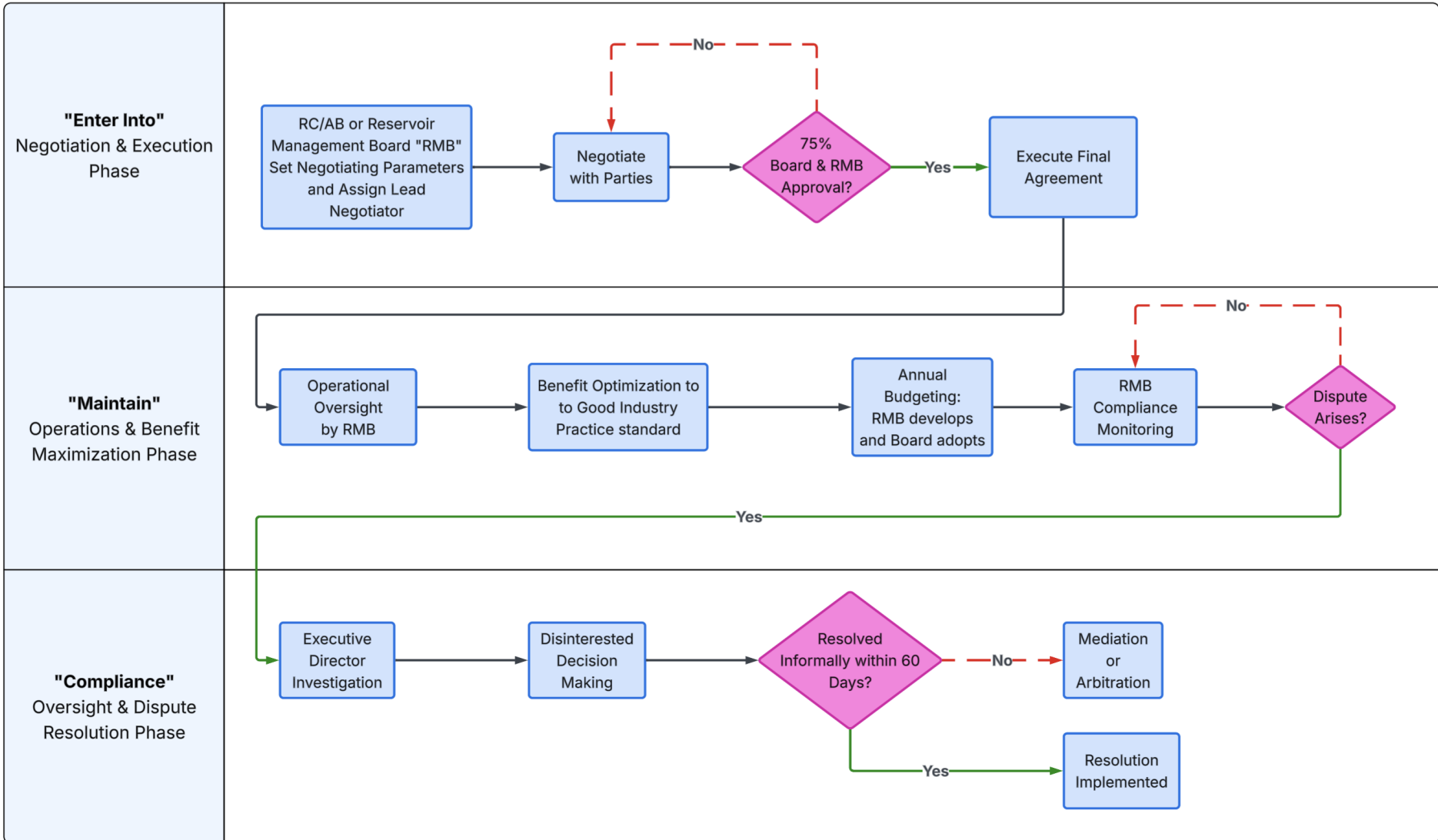

# Release of Water / Point of Delivery

Issue Paper 5



# Summary of Comments and Staff Recommendation

## Comment/Issue

Some Participants requested moving the "Delivery Point" from Funks Reservoir/TRR to the Sacramento River or South Delta.

## Staff Recommendation

- Keep the Points of Delivery at Funks Reservoir or the Terminal Regulating Reservoir.
- Commit the Authority to assure conveyance of Sites water from the Delivery Point to a Participant's Secondary Delivery Point.

# Rationale for Staff Recommendation

- **Risk Management:** Maintains the principle that conveyance risks and costs remain with the specific Participant rather than other partners.
- **Financial Integrity:** The Authority has no capability to solely bear the risks associated with delivery shortfalls.
- **Operational Clarity:** Replacing "Operations Plan" with "provisions of this Contract" gives stronger contractual weight to delivery rights.
- **RMB Operational Oversight:** Recognition that the RMB provides operations direction to Authority staff

# Contract Sections Affected

- **Sections 4.6.2 & 4.6.3:** Updated to include "best efforts" language and shift oversight to the Contract itself.
- **Sections 4.3.5 & 4.3.6:** New explanations of first and second
- **Definitions:** Addition of "Available Downstream Capacity" to replace the concept of "unused capacity". priority use for Downstream Facilities.
- **Sections 4.1.3, 4.6, & 4.11.3:** General conforming changes.

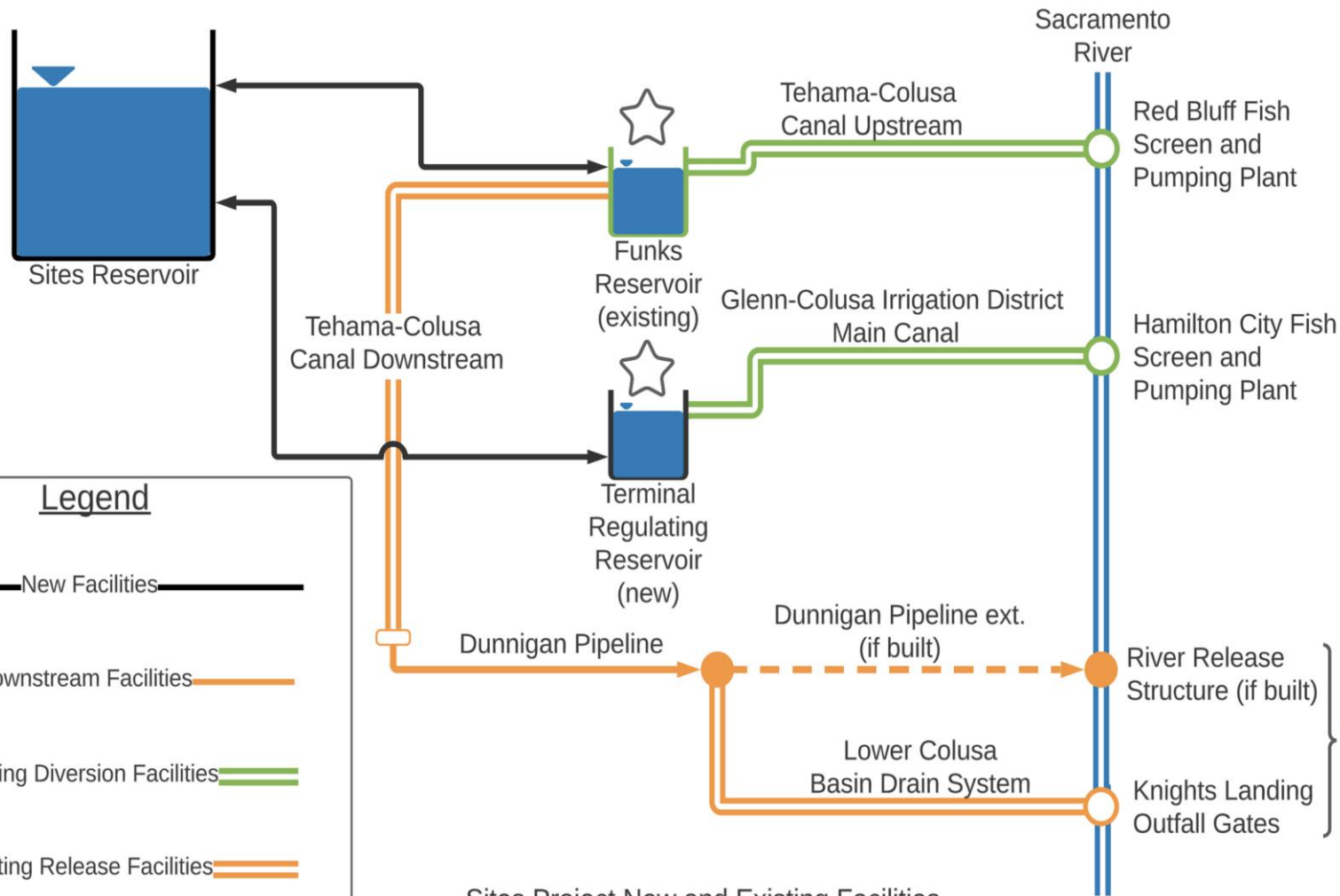

Legend

— New Facilities —

— Downstream Facilities —

— Existing Diversion Facilities —

— Existing Release Facilities —

☆ Possible Delivery Point

Sites Project New and Existing Facilities  
with Possible Delivery Points

# Agree on direction

Screen sharing



# Next Steps

- Incorporate today's direction and other detailed comments into the B&O followed by quick review from Participants
- June 15: Post Final Review Draft of B&O
- June 26: RC/AB discussion of Execution Version of B&O, final input
- July 13: Post Execution-ready B&O
- July 24: RC/AB accept B&O, JPA, and Bylaws to include with Resolution to Offer Capacity

Questions?